

Screw Extraction Set.

Instruments for removing Synthes screws.

Handling
Technique



Table of Contents

Introduction	Removal of implants	3
	System description	4
	Instruments	6

Handling Technique	Preoperative planning	12
	Removal of intact screws	13
	Removal of screws with damaged screw recess	17
	Removal of broken screws	24
	Removal of jammed screws	32
	Removal of cannulated screws	44

Product Information	Ordering information	48
----------------------------	----------------------	----

Warning

This description is not sufficient for immediate application of the instrumentation. Instruction by a surgeon experienced in handling these instruments is highly recommended.

Removal of implants

For many patients, Implant removal often represents the true completion of fracture treatment. While giving due concern to the patient's own wishes, the expense, utility, and risks of removal of the implants must be weighed up. The implications of leaving the implant in place should always be explained to the patient.

As a matter of principle, implants can be removed once the fracture has healed and the load capacity has been re-established.

In the case of implant removal, complications may arise for a variety of reasons and it is important that the surgeon should be prepared for this. As well as the normal extraction instruments, such as screwdrivers, instruments to extract damaged and broken screws should also be readily available.

The Synthes Screw Extraction Set is a comprehensive set containing all necessary instruments.

Recommended literature

Rüedi T.P. et al (2001): Implant removal – general comments. AO Principles of Fracture Management, pgs 729–731

Müller-Färber J (2003): Die Metallentfernung nach Osteosynthesen. In: Der Orthopäde, Book 11, pgs 653–670

Georgiadia G (2004): Removal of the Less Invasive Stabilization System. In: Journal of Orthopaedic Trauma, Volume 18, pgs 562–564

Screw Extraction Set.

Instruments for Removing Synthes Screws.

System description

The screw extraction set contains instruments required for removing intact screws or damaged screws that are difficult to remove. The size-related screw extraction instruments (e.g. screwdriver shafts, conical extraction screws) are divided into three modules. The general extraction instruments that can be used for all screw sizes are on the base of the set.

Properties

Modular

The modular design ensures that assembly is ideally suited to requirements. The entire contents or alternatively individual components can be ordered. It is easy to ensure that the set is always complete.

Safe

The clear layout makes the instruments easy to locate, thereby reducing the danger of selecting the wrong instrument.

Complete

All existing Synthes screws can be removed with the instruments supplied in the screw extraction set. This prevents delays caused by missing or incorrect instruments.



Screw extraction modules

The screw extraction modules contain screwdriver shafts for all Synthes screw sizes and drives, as well as extraction instruments for extracting broken and damaged screws. The instruments are divided into three modules, depending on the screw size.

- Screw extraction module for screws \varnothing 1.0/1.3/1.5/2.0/2.4/2.7/3.0
- Screw extraction module for screws \varnothing 3.5/4.0/4.5
- Screw extraction module for screws \varnothing 5.0/6.0/6.5/7.0/7.3

Field of application

To remove all screws with the following drives:

Hex: 1.5 mm, 2.5 mm, 3.5 mm and 4.0 mm

Stardrive: T4, T5, T6, T8, T15, T25 and T40

Cruciform: 1.0 mm, 1.3 mm, 1.5 mm, 2.0 mm and 2.4 mm

To remove all steel and titanium screws:

- Cortex screws
- Cancellous bone screws:
- Shaft screws
- Cannulated screws
- Locking screws
- Locking bolts



Instruments

The three screw extraction modules are set up in a similar way. In simplified terms, the following instruments are available in the following individual modules (68.900.021, 68.900.022 and 68.900.023).

To remove intact screws

Screwdriver shafts

(Hex, Stardrive and cruciform):

To remove intact screws (along with the T-handle with quick coupling, handle with quick coupling, handle with mini quick coupling, universal chuck, small with T-handle or lengthening for screwdriver shaft)



To remove broken screws

Hollow Reamer, complete, anticlockwise

To expose broken screw shafts



Spare reamer tube for hollow reamer, anticlockwise



Extraction bolts, anticlockwise to remove broken exposed screw shafts



To remove screws with a damaged screw recess

309.510 **Extraction screws**, conical,
309.520 anticlockwise:
309.530 To remove screws with a damaged screw
309.521 recess (the conical tip of the extraction
 screw grasps into the screw recess and the
 screw can be removed by turning anti-
 clockwise)



311.440 **T-Handle** with Quick Coupling



310.950 **Handle with Mini Quick Coupling**
(only in extraction module for screws
Ø 1.0/1.3/1.5/2.0/2.4/ 2.7/ 3.0)



Instruments first insert

Modules and general extraction instruments

First insert: Modules and general extraction instruments



398.650

Pliers for Screw Removal,
length 205 mm
To remove screws or broken screws with protruding screw shaft (large fragment)



398.651

Pliers for Screw Removal, narrow
To remove screws or broken screws with protruding screw shaft or to expose deeper, broken screw shafts (small fragment).

The sharp edges of the tip of the pliers act as an awl

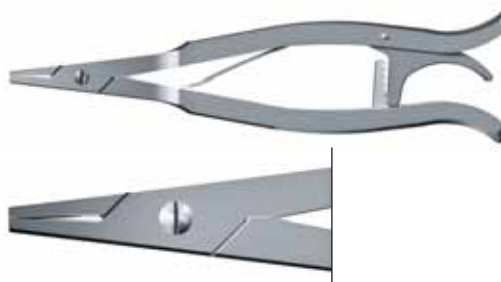

399.680

Gouge, width 10 mm
To expose the stump of shallow seated, broken screws



311.431

Handle with Quick Coupling



393.105 **Universal Chuck**, small, with T-Handle

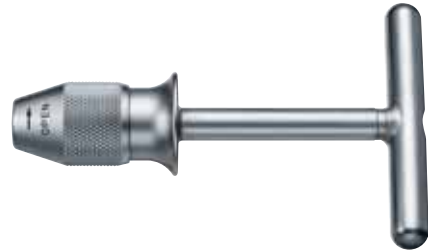

03.900.001 **Sharp Hook**, straight and bent
319.390 To clean the screw recess



03.900.011 **Extraction Pliers for Screws**,
03.900.013 small and large
To grasp screws behind the screw head



03.900.002 **Lengthening for Screwdriver Shaft**
To extend instruments with AO quick coupling (e.g. screwdriver shafts from the modules)



Instruments second insert

Modules and general extraction instruments

Second insert

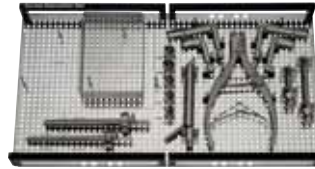

Drill Suction Device

With attachable drill sleeves for drill bits \varnothing 2.5/3.5/4.0/4.8 and 6.0 mm

Allows efficient suction removal of drill chips, while cooling and guiding the drill



03.607.110 Drill Suction Device

03.607.025 Drill Sleeve 2.5, clip-on,
for no. 03.607.110

03.607.035 Drill Sleeve 3.5, clip-on,
for no. 03.607.110

03.607.040 Drill Sleeve 4.0, clip-on,
for no. 03.607.110

03.607.048 Drill Sleeve 4.8, clip-on,
for no. 03.607.110

03.607.060 Drill Sleeve 6.0, clip-on,
for no. 03.607.110

68.900.024 **Auxiliary Bin** for Extraction Set for the
top or bottom base



Soft Tissue Spreader

Forceps system for a minimally invasive approach through stab incisions. Consisting of

- 03.400.000 Forceps for Soft Tissue Spreader
- 03.400.004 Retractor right, 35 mm
- 03.400.005 Retractor left, 35 mm
- 03.400.010 Retractor right, 75 mm
- 03.400.011 Retractor left, 75 mm
- 03.400.024 Trocar 35 mm
- 03.400.030 Trocar 75 mm

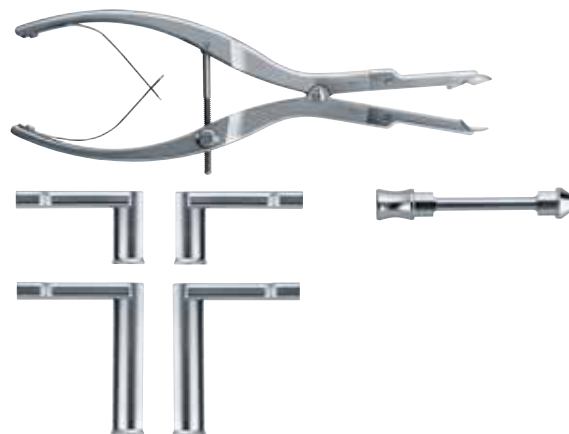

Carbide Drill Bit

- 309.004S \varnothing 4.0 mm, length 50 mm
- 309.006S \varnothing 6.0 mm, length 50 mm
To drill off the screw head (titanium and instrument steel)



HSS Drill Bit

- 309.503S \varnothing 2.5 mm, length 57 mm
- 309.504S \varnothing 3.5 mm, length 70 mm
- 309.506S \varnothing 4.8 mm, length 86 mm
To drill off the screw head (implant steel)
or to pre-drill the screw recess



Extension for Carbide Drill Bit

- 03.607.104 \varnothing 4.0 mm
- 03.607.106 \varnothing 6.0 mm



Handling Technique

Preoperative planning

To ensure that the suitable extraction instruments can be obtained, the surgeon should be acquainted with the following prior to the implant removal:

- Implant manufacturer
- Implant type
- Time of implantation
- Material (steel, titanium)
- Recess geometry and dimension of the screws
(Hex, Stardrive or cruciform)
- Screw diameter
- Any visible damage to the implant
(e.g. broken screw shaft)

Handling Technique

Removal of **intact** screws (minimally invasive)

Required instruments

03.400.000–030	Soft Tissue Spreader
319.390	Sharp Hook
03.900.002	Sharp Hook, straight
03.900.011	Extraction Pliers, small, for Screws
03.900.013	Extraction Pliers, large, for Screws
03.900.002	Lengthening for Screwdriver Shaft, length 160 mm
311.440	T-Handle with Quick Coupling
393.105	Universal Chuck, small, with T-Handle
	Corresponding Screwdriver Shaft

1

Incision and access

Make a stab incision orthogonally to the screw to be removed (along the length of the plate) and introduce the soft tissue spreader with trocar into the opening. Once the instrument touches the screw, open the soft tissue spreader and remove the trocar. Open the soft tissue spreader until the screw to be removed can be easily accessed.

Note: Use either the short or long retractors of the soft tissue spreader, depending on the depth of the incision. If the screws are on the surface the soft tissue spreader does not need to be used.

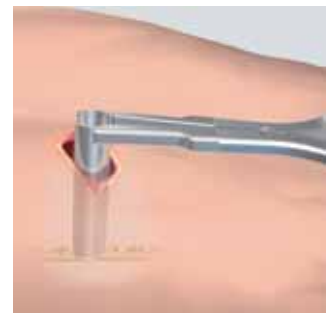
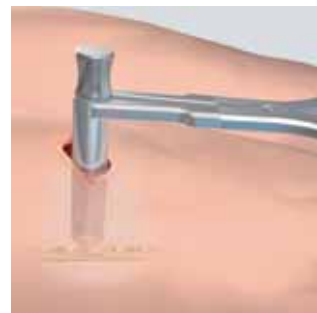

Handling Technique

Removal of **intact** screws (minimally invasive)

2

Clean screw recess

Free the screw recess from ingrown scars and bone tissue using the sharp hook to ensure that the screwdriver can be fully inserted. Check the condition and the geometry of the recess of the exposed screw head.

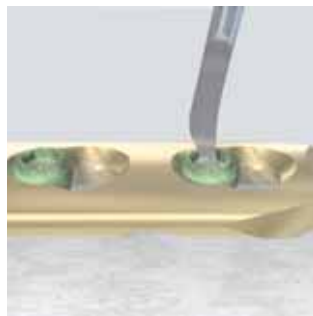
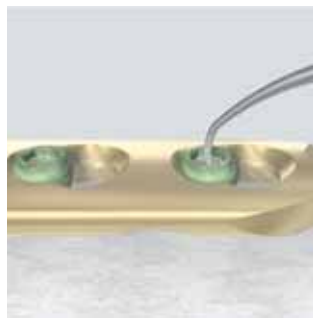

Note: Use the sharp hook to clean the recess if the soft tissue is not deep. If the screw is deeper use the straight sharp hook.

3

Remove screw

Connect the appropriate screwdriver shaft to the T-Handle with Quick Coupling. If the screw is deep in the tissue, attach the lengthening for Screwdriver Shaft.

Option: Instead of using the T-Handle with Quick Coupling, the Universal Chuck, small with T-Handle (1) or the Handle with Quick Coupling (2) can be used. Connect the mini fragment screwdriver shafts (Mini Quick Coupling) to the Handle with Quick Coupling (3).



Insert the screwdriver fully into the screw recess. If necessary, lightly tap the screwdriver with a hammer.

Important: It is essential that you ensure that the screwdriver shafts are not damaged and are always inserted into the same axis as the screw to be removed. If the screwdriver is not inserted straight or if it is blunt, it can damage the screw recess when turned.



Handling Technique

Removal of **intact** screws (minimally invasive)

Unscrew the screw.

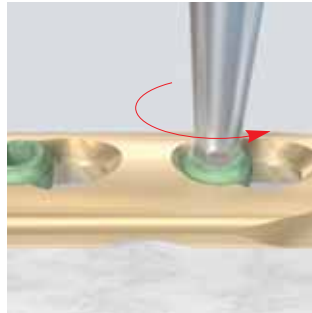

To ensure that the loosened screw is not lost in the soft tissues or strips its thread in the bone, it can be held in position by extraction pliers for screws. Guide the extraction pliers along the screwdriver to the screw head and grasp the screw directly behind the head. Use the small extraction pliers for small fragment screws and the large extraction pliers for large fragment screws.

When all screws have been removed the plate/internal fixator can be removed through the implant access (minimally invasive).

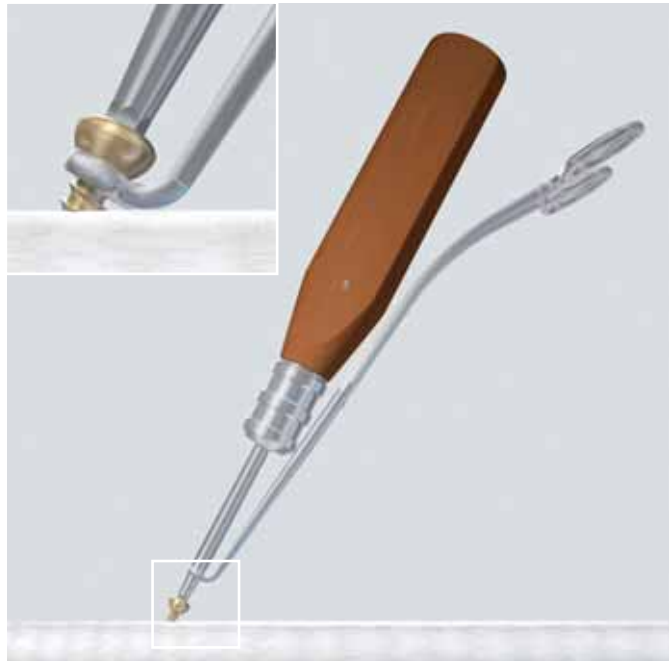

Handling Technique

Removal of screws with a **damaged recess**

Situation A

Screwdriver turns freely in the recess

Required instruments

309.510, 309.520, 309.530, 309.521	Extraction Screws, conical, various sizes
311.440	T-Handle with Quick Coupling



1 and 2

Incision, access and cleaning the recess

If possible, this is carried out as described on page 13 (minimally invasive). If a minimally invasive removal is not an option, select an open approach.

Handling Technique

Removal of screws with **damaged recess**

Situation A

Screwdriver turns freely in the recess

3

Select a suitable conical extraction screw

The tables below can be used for guidance. Table 1 groups according to recess geometry and size (Hex and Stardrive). Table 2 groups according to screw diameter and recess geometry/size. It is not always possible to clearly allocate the extraction screw.

Note: Always use the extraction screw with the largest possible diameter.

Table 1

Conical extraction screw/ recess dimension



















Recess										
	1.5 Hex.	2.5 Hex.	3.5 Hex.	4.0 Hex.	T4	T6	T8	T15	T25	T40
 309.510	•		•			•	•	•		•
 309.520		•	•					•	•	•
 309.530			•	•					•	•
 309.521		•						•		•

Table 2

Conical extraction screw/recess diameter

Ø	1.0/1.3/1.5 mm (Cruci.)	1.5 mm (1.5 Hex.)	2.0 mm (Hex.)	2.0 mm (1.5 Hex.)	2.0 mm (T6)	2.4 mm (Cruci.)	2.4 mm (T8)	2.7 mm (2.5 Hex.)	2.7 mm (T8)	2.7 mm (T15)	3.4 mm (3.5 Hex.)	3.5 mm (2.5 Hex.)	3.5 mm (T15)	3.9 mm (2.5 Hex.)	3.9 mm (3.5 Hex.)	4.0 mm (2.5 Hex.)	4.0 mm (3.5 Hex.)	4.0 mm (T25)	4.5 mm (3.5 Hex.)	4.9 mm (3.5 Hex.)	5.0 mm (3.5 Hex.)	5.0 mm (T25)	6.0 mm (T25)	6.5 mm (3.5 Hex.)
 309.510		•		•	•		•		•	•	•		•	•	•		•		•	•	•		•	•
 309.520								•		•	•	•	•	•	•	•	•	•	•	•	•	•	•	•
 309.530											•				•		•	•	•	•	•	•	•	•
 309.521								•		•		•	•	•	•	•	•							

4

Remove screw

Connect the conical extraction screw with the T-Handle with Quick Coupling. If the screw is deep in the tissue, attach the lengthening for screwdriver shaft.



Insert the tip of the conical extraction screw into the screw recess and hold it as vertical as possible. **Turn anticlockwise, exerting pressure**, until the extraction screw grasps into the screw recess. Continue to turn anticlockwise and remove the screw.

Important: During insertion ensure that enough axial pressure is exerted and retain the axis. Only use sharp-edged extraction screws (recommendation: one extraction). Do not use extraction screws with power tools.



Handling Technique

Removal of screws with **damaged recess**

Situation B

Screwdriver and conical extraction screw turn freely in the recess

If the screwdriver and the conical extraction screw wear down the recess of the screw, you can attempt to lightly pre-drill the screw recess and to anchor the conical extraction screw deeper.

Important information on drilling with metal drill bits:

- Drill bits may not be reprocessed or resterilized. They are designed for **single use** only.
- Metal drill bits are hard and brittle. To prevent breakages start drilling with the drill bit already revolving and maintain the chosen drill axis throughout the entire drilling process.
- When drilling, cool with the drill suction device and aspirate the drill chips.

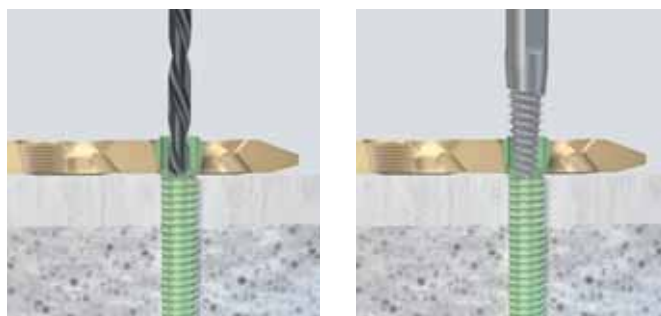

Required instruments

309.503S	HSS Drill Bit Ø 2.5 mm
----------	------------------------

309.504S	HSS Drill Bit Ø 3.5 mm
----------	------------------------

03.607.110	Drill Suction Device
------------	----------------------

03.607.025	Drill Sleeve 2.5, clip-on, for no. 03.607.110
------------	--------------------------------------------------

03.607.035	Drill Sleeve 3.5, clip-on, for no. 03.607.110
------------	--------------------------------------------------

309.510, 309.520, 309.530, 309.521	Extraction Screws, conical, various sizes
---------------------------------------	----------------------------------------------

311.440	T-Handle with Quick Coupling
---------	------------------------------

1 and 2

Incision, access and cleaning the recess

This is carried out, if possible, as described on page 13 (minimally invasive). If a minimally invasive removal is not an option, select an open approach.

3

Prepare Drill Suction Device

Drilling standard and locking screws causes drill chips; these need to be suctioned away. It is also important to cool the drill bit during the drilling process. The use of the drill suction device allows an efficient aspiration of the drill chips while at the same time cooling the drill bit.

Before drilling attach the appropriate drill sleeve to the drill suction device (for \varnothing 2.5/3.5 mm). Then connect the drill suction device to the irrigation system and the vacuum pump. To release the drill sleeve, press the side flange.



Handling Technique

Removal of screws with a **damaged recess**

Situation B

Screwdriver and conical extraction screw turn freely in the recess

4

Select the appropriate HSS Drill Bit

- Small fragment: HSS Drill Bit \varnothing 2.5 mm
- Large fragment: HSS Drill Bit \varnothing 3.5 mm



5

Drill screw recess

Switch on the rinsing equipment and the vacuum pump. Position the drill suction device on the relevant screw. Insert the drill bit into the drill sleeve, start up the drill and then start the drilling process. Carefully pre-drill the screw recess.

Important: Do not interrupt the water supply. Ensure that the supply and waste hose is not bent.



6

Remove screw

Remove screw with the conical extraction screw as described on page 19.

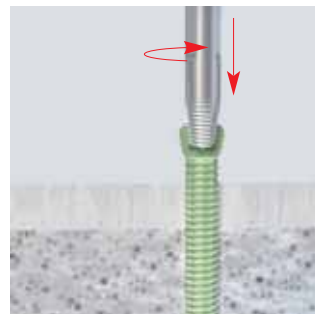

Handling Technique

Removal of **broken** screws

Situation A

Screw is broken behind the screw head and shaft is visible on the surface or slightly below the surface

Required instruments

399.680	Gouge
398.650	Pliers for Screw Removal
398.651	Pliers for Screw Removal, narrow

1

Incision and access

This is carried out, if possible, as described on page 13 (minimally invasive). If a minimally invasive removal is not an option, select an open approach.

2

Exposing the screw shaft

Use the gouge to remove the bone surrounding the screw shaft to approximately 5 mm in depth.



Alternative: Expose the screw shaft with the Pliers for Screw Removal (narrow), but using the slightly opened pliers as an awl (sharp edges on the outside of the clamps).



Handling Technique

Removal of **broken** screws

Situation A

Screw is broken behind the screw head and shaft is visible on the surface or slightly below the surface

3

Remove screw

Rotate screw out with Pliers for Screw Removal (398.650 or 398.651)

Note: The Pliers for Screw Removal, narrow (398.651) require less space to grasp the screw shaft than the Pliers for Screw Removal (398.650), but is less stable.

Important: Remove the screw stump by **rotating it out – do not pull or bend.**

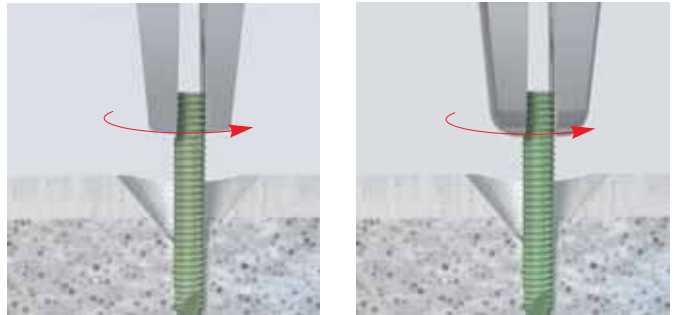

Situation B

Broken screw is not on the surface

Required instruments

309.150, 309.200, 309.250, 309.035, 309.450, 309.065	Hollow reamer, complete various sizes
309.090, 309.190, 309.290, 309.039, 309.090, 309.069	Extraction Bolt, various sizes
311.440	T-Handle with Quick Coupling

1

Incision and access

This is carried out, if possible, as described on page 13 (minimally invasive). If a minimally invasive removal is not an option, select an open approach.

Handling Technique

Removal of broken screws

Situation B



Broken screw is not on the surface

2

Select hollow reamer and extraction bolt

The following table shows which extraction instruments can be used to remove the various screws (increasing screw diameter from left to right). If several instruments can be used, select the one with the lowest article number (smallest external diameter).

Hollow reamer and extraction bolt/screw diameter

Ø	Hollow reamer and extraction bolt/screw diameter																									
	1.0/1.3/1.5 mm (Cruci.)	1.5 mm (1.5 Hex.)	2 mm (Cruci.)	2 mm (1.5 Hex.)	2 mm (T6)	2.4 mm (Cruci.)	2.4 mm (T8)	2.7 mm (2.5 Hex.)	2.7 mm (T8)	2.7 mm (T15)	3.4 mm (3.5 Hex.)	3.5 mm (2.5 Hex.)	3.5 mm (T15)	3.9 mm (2.5 Hex.)	3.9 mm (3.5 Hex.)	4.0 mm (2.5 Hex.)	4.0 mm (3.5 Hex.)	4.0 mm (T25)	4.5 mm (3.5 Hex.)	4.9 mm (3.5 Hex.)	5.0 mm (3.5 Hex.)	5.0 mm (T25)	6.0 mm (T25)	6.5 mm (3.5 Hex.)		
	309.150	•	•	•	•	•																				
	309.200			•	•	•																				
	309.250						•	•	•	•																
	309.035										•	•	•	•	•	•	•	•								
	309.450															•	•	•	•	•	•	•	•			
	309.065																							•	•	
	309.090	•	•																							
	309.190			•	•	•																				
	309.290						•	•	•	•																
	309.039										•	•	•	•	•	•	•	•								
	309.490															•	•	•	•	•	•	•	•			
	309.069																							•	•	

3

Assemble hollow reamer

The hollow reamer (complete) consists of three individual parts: reamer tube, centring pin and shaft.

1. Connect the centring pin and the shaft (left-hand thread)
2. Screw the reamer tube over the centring pin (left-hand thread).

Important: There is no thread connection between the space centring pin and the shaft for hollow reamers 309.150, 309.200 and 309.250. In these models, the space centring pin is positioned loosely in the hollow reamer. The reamer tube and the shaft are then screwed together (left-hand thread).

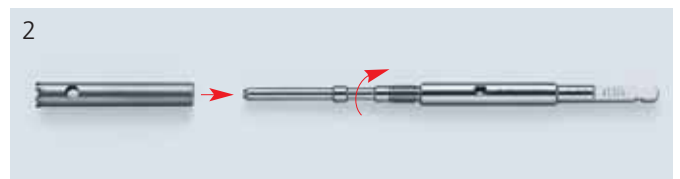
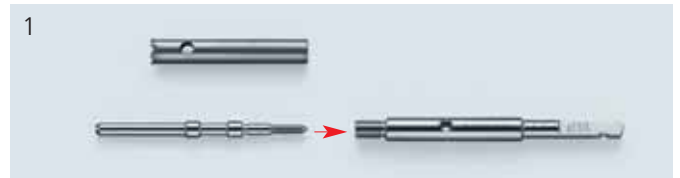

Connect the instruments with the T-Handle with Quick Coupling. If the screw is deep in the tissue, attach the lengthening for screwdriver shaft.

Note: If the screw shaft has broken off less than approximately 5 mm below the bone surface, the hollow reamer can also be used without the centring pin. In this case, only connect the reamer tube and the shaft (left-hand thread).

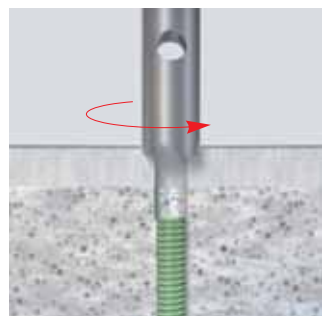

Handling Technique

Removal of **broken** screws

Situation B

Broken screw is not on the surface

4

Expose the screw shaft

Guide the space centring pin into the canal of the broken screw and turn the hollow reamer anticlockwise. Remove the centring pin when it reaches the screw fragment. Then continue to screw without the space centring pin approximately 5 mm above the broken screw.

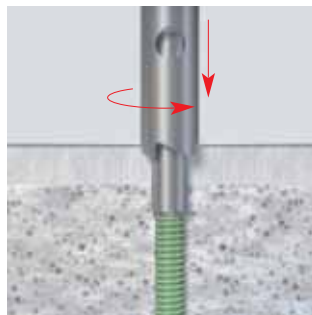

5

Remove screw

Connect the extraction bolt with the T-Handle with Quick Coupling. If the screw is deep in the tissue, attach the lengthening for screwdriver shaft.



Position the extraction bolt above the broken screw. Rotate anticlockwise while maintaining pressure and holding as vertical as possible. This ensures a secure connection between the conical shape of the thread of the extraction bolt and the shaft of the screw. Turn anticlockwise until the screw shaft is completely removed.

Important: The hollow reamer and the extraction bolt are left-turning (to be turned anticlockwise). During insertion ensure that enough axial pressure is exerted and maintain the axis. Only use instruments with sharp edges. It is possible to use the hollow reamer with power tools, but this should be done very carefully.

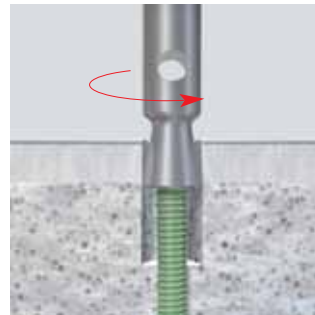

Handling Technique

Removal of **jammed** screws (in plates)

Drill bits for metal, HSS or carbide, are designed for drilling standard and locking screws that are blocked in the plate. Before using a drill, try to remove the blocked screw with the conical extraction screw (as described on page 17–19).

Do not use excessive strength, as the extraction screw could otherwise break. If the conical extraction screw does not grip, you can try to slightly pre-drill the recess and to anchor the conical extraction screw deeper (as described on page 20-23). If it is still not possible to remove the screw, the screw head has to be drilled off and there are then two possible options

- Situation A: Blocked screw **without** broken instrument in recess
- Situation B: Blocked screw **with** broken instrument in recess (e.g. tips of screwdrivers, extraction screws).

Important information on drilling with metal drill bits:

- Drill bits may not be reprocessed or resterilized. They are designed for **single use** only.
- Metal drill bits are hard and brittle. To prevent breakage start drilling with the drill bit already revolving and maintain the chosen drill axis throughout the entire drilling process.
- When drilling, cool with the drill suction device and also aspirate the drill chips.

Situation A
Jammed screw without broken
instrument in recess

Required instruments

309.503S	HSS Drill Bit Ø 2.5 mm
309.504S	HSS Drill Bit Ø 3.5 mm
309.506S	HSS Drill Bit Ø 4.8 mm
309.004S	Carbide Drill Bit Ø 4 mm
309.006S	Carbide Drill Bit Ø 6 mm
03.607.104	Extension for Carbide Drill Bit Ø 4.0 mm
03.607.106	Extension for Carbide Drill Bit Ø 6.0 mm
03.607.110	Drill Suction Device
03.607.025	Drill Sleeve 2.5, attachable, for no. 03.607.110
03.607.035	Drill Sleeve 3.5, clip-on, for no. 03.607.110
03.607.040	Drill Sleeve 4.0, clip-on, for no. 03.607.110
03.607.048	Drill Sleeve 4.8, clip-on, for no. 03.607.110
03.607.060	Drill Sleeve 6.0, clip-on, for no. 03.607.110

Handling Technique

Removal of **jammed** screws (in plates)

Situation A

Blocked screw without broken instrument in recess

1

Incision and access

This is carried out, if possible, as described on page 13 (minimally invasive). If a minimally invasive removal is not an option, select an open approach.

2

Select a suitable drill bit and attach it to the power tool

Important: Select the HSS drill bit to drill out screws from steel implants. Drill out titanium screws with carbide drill bits. To remove broken instruments from the screw recess (e.g. tips of screwdrivers, extraction screws), only use the carbide drill bits.

Carbide Drill Bit

- Titanium
- Instrument steel



HSS Drill Bit

- Implant steel



A detailed overview of the drill bits to be used is shown in the following table

Screw Sizes	Drills			Drills suitable for		
	Art. No.	Ø	Type	TiCP, TAN, TAV	Implant steel	Instrument steel
3.5, 4.0	309.503S	2.5 mm	HSS	++	++	–
3.5, 4.0, 4.5, 5.0	309.504S	3.5 mm	HSS	++	++	–
3.5, 4.0, 4.5, 5.0	309.004S	4.0 mm	Carbide	++	+	+
5.0, 6.5, 7.0, 7.3	309.506S	4.8 mm	HSS	++	++	–
5.0, 6.5, 7.0, 7.3	309.006S	6.0 mm	Carbide	++	+	+

- ++ good drilling properties
- + adequate drilling properties
- not recommended

Attach drill bit to the Universal chuck of the power tool and tighten.



If the screw is deep, extensions can be used for the carbide drill bits (for drill bits \varnothing 4.0 mm and \varnothing 6.0 mm).



Handling Technique

Removal of **jammed** screws (in plates)

Situation A

Jammed screw without broken instrument in recess

Attach the extension to the universal chuck of the power tool (1) and tighten (2). Then open the sleeve of the extension (3) by turning the nut (left-hand thread).

Attach the drill bit to the extension (4). Ensure that the surfaces of the drill bit fit onto the corresponding surfaces in the sleeve of the extension. Then **manually** close the sleeve (5). It is not advisable to tighten the nut with a pin wrench. When releasing the nut the pin wrench may, however, be useful, as the drilling process itself can tighten the left-hand thread of the extension.

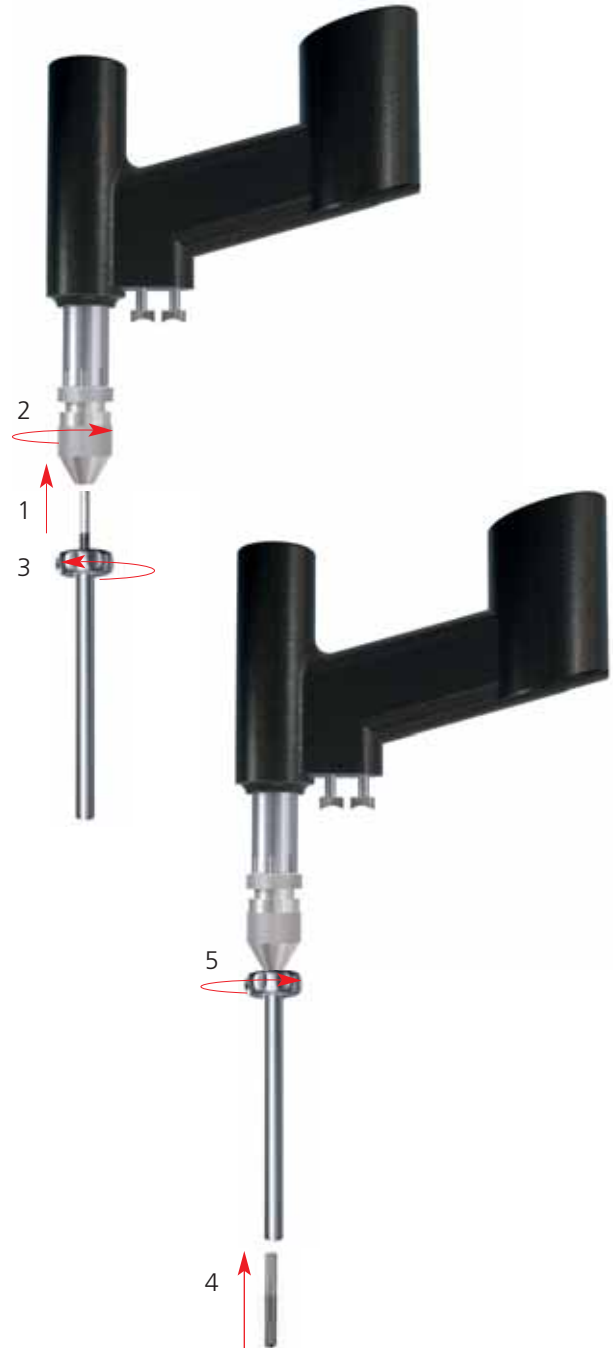

3

Prepare Drill Suction Device

Drilling standard and locking screws causes drill chips; these need to be suctioned away. It is also important to cool the drill bit during the drilling process. The use of the drill suction device allows an efficient aspiration of the drill chips while at the same time cooling the drill bit.

Before drilling attach the appropriate drill sleeve to the drill suction device (for \varnothing 2.5/3.5/4.0/4.8/6.0 mm). Then connect the drill suction device to the irrigation system and the vacuum pump. To release the drill sleeve, press the side flange.



Handling Technique

Removal of **jammed** screws (in plates)

Situation A

Jammed screw without broken instrument in recess

4

Drill off screw head

Switch on the rinsing equipment and the vacuum pump. Position the drill suction device on the relevant screw. Insert the drill bit into the drill sleeve, start up the drill and then start the drilling process. Carefully drill off the screwhead.

Align the axis of the drill according to the axis of the screw and maintain the selected drilling axis throughout the drilling process. Drill until the screw head is released from the screw shaft.

Important: Do not interrupt the water supply. Ensure that the supply and waste hose is not bent.

Remove the plate when it is no longer held in place by any screw.

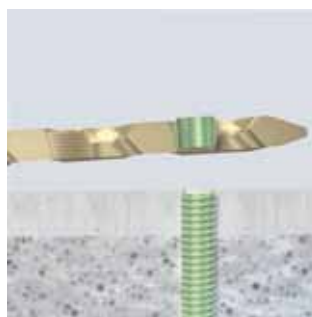
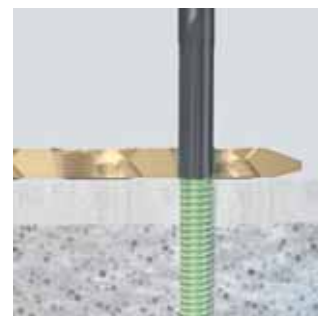

5

Remove remaining screw shaft

Proceed as in the case of the broken screw.

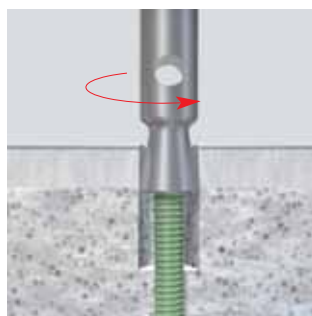

Situation B

Jammed screw with broken instrument in recess

Incision and access

309.004S	Carbide Drill Bit Ø 4 mm, sterile
309.006S	Carbide Drill Bit Ø 6 mm, sterile
03.607.110	Drill Suction Device
03.607.040	Drill Sleeve 4.0, clip-on, for no. 03.607.110
03.607.060	Drill Sleeve 6.0, clip-on, for no. 03.607.110
03.607.104	Extension for Carbide Drill Bit Ø 4.0 mm
03.607.106	Extension for Carbide Drill Bit Ø 6.0 mm
398.650	Pliers for Screw Removal
398.651	Pliers for Screw Removal, narrow

1

Incision and access

This is carried out, if possible, as described on page 13 (minimally invasive). If a minimally invasive removal is not an option, select an open approach.

First attempt to remove the broken part of the instrument with a sharp hook and/or pliers. If this attempt fails proceed with the next step.

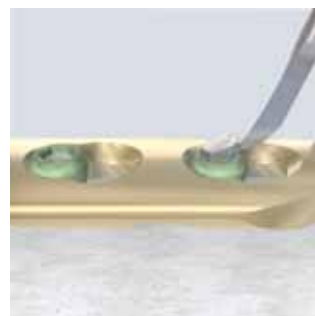

Handling Technique

Removal of **jammed** screws (in plates)

Situation B

Jammed screw with broken instrument in recess

2

Select a suitable drill bit and attach it to the power tool

Please refer to the table below to select the drill bit

Important: To remove broken instruments from the screw recess (e.g. tips of screwdrivers, extraction screws), only use the carbide drill bits.

Carbide Drill Bit

- Titanium
- Instrument steel



Screw sizes	Drills			Drills suitable for		
	Art. no.	Ø	Type	TiCP, TAN,TAV	Implant steel	Instrument steel
3.5, 4.0	309.503S	2.5 mm	HSS	++	++	-
3.5, 4.0, 4.5, 5.0	309.504S	3.5 mm	HSS	++	++	-
3.5, 4.0, 4.5, 5.0	309.004S	4.0 mm	Carbide	++	+	+
5.0, 6.5, 7.0, 7.3	309.506S	4.8 mm	HSS	++	++	-
5.0, 6.5, 7.0, 7.3	309.006S	6.0 mm	Carbide	++	+	+

- ++ good drilling properties
- + adequate drilling properties
- not recommended

Attach drill bit to the universal chuck of the power tool and tighten.



If the screw is deep, extensions can be used for the carbide drill bits (for drill bits \varnothing 4.0 mm and \varnothing 6.0 mm).

Attach the extension to the universal chuck of the power tool (1) and tighten (2). Then open the sleeve of the extension (3) by turning the nut (left-hand thread).

Attach the drill bit to the extension (4). Ensure that the surfaces of the drill bit fit onto the corresponding surfaces in the sleeve of the extension. Then **manually** close the sleeve (5). It is not advisable to tighten the nut with a pin wrench. When releasing the nut the pin wrench may, however, be useful, as the drilling process itself can tighten the left-hand thread of the extension.



Handling Technique

Removal of **jammed** screws (in plates)

Situation B

Jammed screw with broken instrument in recess

3

Prepare Drill Suction Device

Drilling standard and locking screws causes drill chips; these need to be suctioned away. It is also important to cool the drill bit during the drilling process. The use of the drill suction device allows an efficient aspiration of the drill chips while at the same time cooling the drill bit.

Before drilling attach the appropriate drill sleeve to the drill suction device (for \varnothing 4.0/6.0 mm). Then connect the drill suction device to the irrigation system and the vacuum pump. To release the drill sleeve, press the side flange.



4

Drill off screw head

Switch on the rinsing equipment and the vacuum pump. Position the drill suction device on the relevant screw. Insert the drill bit into the drill sleeve, start up the drill and then start the drilling process. Carefully drill out the screw head.

Align the axis of the drill according to the axis of the screw and maintain the selected drilling axis throughout the drilling process. Drill until the screw head is released from the screw shaft.

Important: Do not interrupt the water supply. Ensure that the supply and waste hose is not bent.

Remove the plate when it is no longer held in place by any screws.

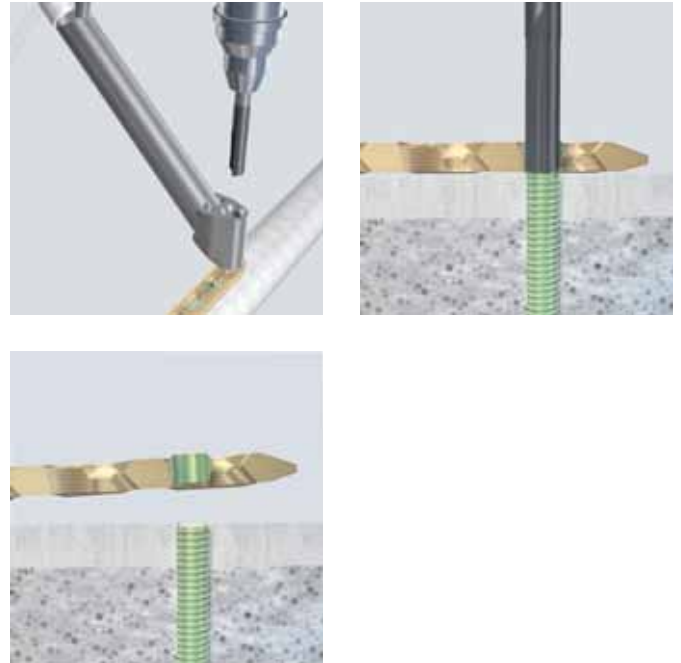

5

Remove remaining screw shaft

Proceed as in the case of the broken screw.

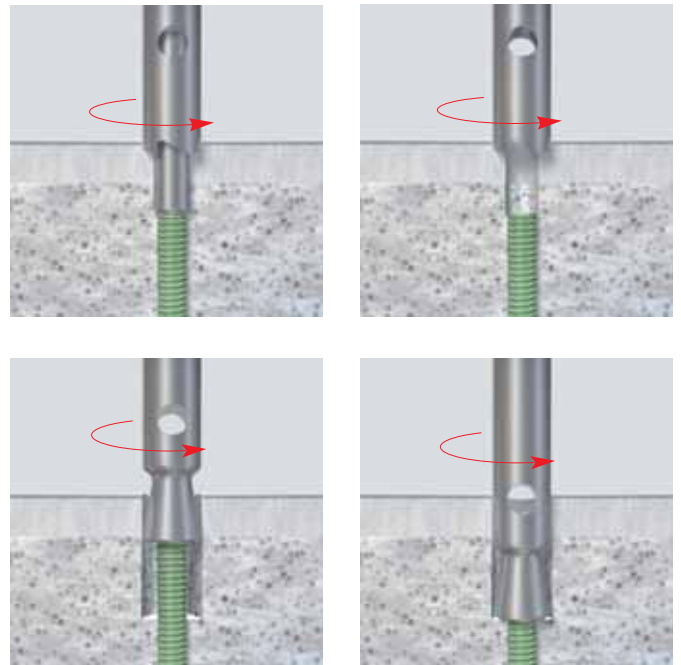

Handling Technique

Removal of **cannulated** screws

Required instruments

319.390	Sharp Hook
03.900.002	Sharp Hook, straight
399.680	Gouge, width 10 mm
398.650	Pliers for Screw Removal
398.651	Pliers for Screw Removal, narrow
03.900.011	Extraction Pliers, small, for Screws
03.900.013	Extraction Pliers, large, for Screws
309.510, 309.520, 309.530, 309.521	Extraction Screws, conical, various sizes
309.150, 309.200, 309.250, 309.035, 309.450, 309.065	Hollow Reamer, complete, various sizes
309.090, 309.190, 309.290, 309.039, 309.090, 309.069	Extraction Bolt, various sizes

General instructions

When removing cannulated screws the process is essentially the same as with non-cannulated screws (see previous section).

- Select a minimally invasive approach (if possible)
- Clean the screw recess with a suitable sharp hook
- Insert the screwdriver fully into the screw recess
- Hold the screw with the extraction pliers etc.



Firmly positioned, cannulated screws

Expose firmly positioned, cannulated screws with the gouge or the pliers for screw removal and then rotate out of position.

You can also try to remove firmly positioned, cannulated screws with a conical extraction screw. Please select the appropriate extraction screws from the following table. In the lines starting with **, the conical extraction screw grips into the cannulation of the cannulated screw. This also allows removal if the screw head has broken off.

Conical extraction screws/screw diameters

∅	2.4 mm (T8)	3.0 mm (Cruci.)	3.0 mm HCS (T8)	3.5 mm (2.5 Hex.)	4.0 mm (2.5 Hex.)	4.5 mm (3.5 Hex.)	6.5 mm (4.0 Hex.)	7.0 mm (3.5 Hex.)	7.3 mm (4.0 Hex.)
309.510	•		•			•		•	
309.520				•	•	•		•	
309.530						•	•	•	•
309.521				•	•				
309.521**							•		•
309.510**						•	•	•	•

** grips into the cannulation of the cannulated screw

Important: Use conical extraction screws with care (danger of breaking)

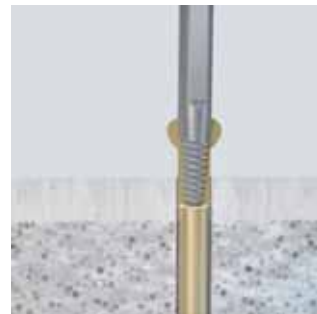

Broken, cannulated screws

Remove broken, cannulated screws either with a conical extraction screw via the cannulation (fig. 1) or with the pliers for screw removal (fig. 2). Remove cannulated screws that are broken off deeper with the hollow reamer and the extraction bolt (fig. 3a and 3b).

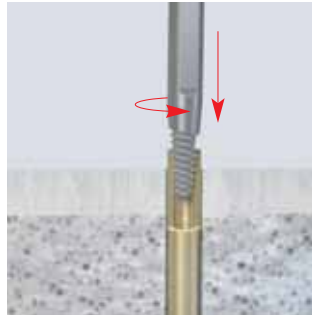

1

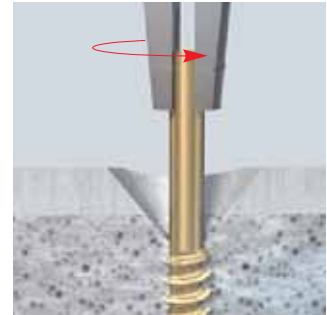

2



3a



3b

When selecting the suitable hollow reamer or extraction bolt it is necessary to decide whether the screw is broken on the shaft (1) or on the thread (2). The external diameter of the screw is smaller in the shaft than in the thread and so smaller hollow reamers and extraction bolts can be used for a break in the shaft. In this case, to place the extraction instruments wide enough over the stump of the screw there must be at least 10 mm of shaft (without thread).

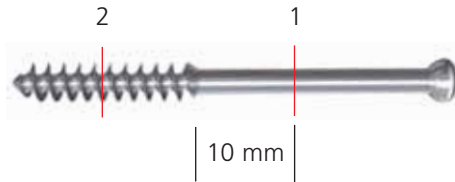

The following table shows which instruments are required for the removal of broken, cannulated screws [•]. The instruments shown in brackets are suitable if the break is in the shaft [(•)].

Extraction instruments for cannulated screws

Ø		2.4 mm (T8)	3.0 mm (Cruci.)	3.0 mm HCS (T8)	3.5 mm (2.5 Hex.)	4.0 mm (2.5 Hex.)	4.5 mm (3.5 Hex.)	6.5 mm (4.0 Hex.)	7.0 mm (3.5 Hex.)	7.3 mm (4.0 Hex.)
	309.510	•		•			•		•	
	309.520				•	•	•		•	
	309.530						•	•	•	•
	309.521				•	•				
	309.521**							•		•
	309.510**						•	•	•	•
	309.150	(•)	(•)							
	309.200			(•)	(•)					
	309.250	•	•	•		(•)				
	309.035		•	•	•	•	(•)			
	309.450					•	•	(•)	(•)	(•)
	309.065							•	•	
	309.090									
	309.190	(•)	(•)	(•)						
	309.290	•	•	•	(•)	(•)				
	309.039		•	•	•	•	(•)			
	309.490						•	(•)	(•)	(•)
	309.069							•	•	•

Ordering Information

Set	Extraction Module	Units
01.900.020	Extraction Set for Standard Screws	
01.900.021	Extraction Module for Screws Ø 1.0/1.3/1.5/2.0/2.4/2.7/3.0	
68.900.021	Extraction Module for Screws Ø 1.0/1.3/1.5/2.0/2.4/2.7/3.0 mm	1
309.150	Hollow Reamer, complete, for Screws Ø 1.0 to 1.5 mm	1
309.200	Hollow Reamer, complete, for Screws Ø 2.0 mm	1
309.250	Hollow Reamer, complete, for Screws Ø 2.4 to 3.0 mm	1
309.080	Spare Reamer Tube, for No. 309.150	1
309.180	Spare Reamer Tube, for No. 309.200	1
309.280	Spare Reamer Tube, for No. 309.250	1
309.090	Extraction Bolt, for Screws Ø 1.0 to 1.5 mm	1
309.190	Extraction Bolt, for Screws Ø 2.0 mm	1
309.290	Extraction Bolt, for Screws Ø 2.4 to 3.0 mm	1
309.521	Extraction Screw, conical	2
309.520	Extraction Screw, conical	2
309.510	Extraction Screw, conical	2
314.030	Screwdriver Shaft, hexagonal, Ø 2.5 mm	1
314.320	Screwdriver Shaft, hexagonal, for Screws Ø 1.5 and 2 mm	1
313.980	Holding Sleeve for Mini Screws, for Nos. 314.300 and 314.320	1
313.822	Screwdriver Shaft Stardrive 1.3, short	1
313.832	Screwdriver Shaft Stardrive 1.5, short	1
313.842	Screwdriver Shaft Stardrive 2.0, short	1
314.451	Screwdriver Shaft Stardrive 2.4, short	1
313.991	Screwdriver Shaft 1.0, cruciform	1
313.992	Screwdriver Shaft 1.3, cruciform	1
313.993	Screwdriver Shaft 1.5/2.0, cruciform	1
03.900.022	Screwdriver Shaft 2.4, cruciform	1
311.440	T-Handle with Quick Coupling	1
310.950	Handle with Mini Quick Coupling	1

Extraction Module		Units
01.900.022	Extraction Module for Screws \varnothing 3.5/4.0/4.5	
68.900.022	Extraction Module for Screws \varnothing 3.5/4.0/4.5 mm	1
309.035	Hollow Reamer, complete, for Screws \varnothing 3.5 to 4.0 mm	1
309.450	Hollow Reamer, complete, for Screws \varnothing 4.0 to 5.0 mm	1
309.038	Spare Reamer Tube, for No. 309.035	1
309.480	Spare Reamer Tube, for No. 309.450	1
309.039	Extraction Bolt, for Screws \varnothing 3.5 to 4.0 mm	1
309.490	Extraction Bolt, for Screws \varnothing 4.0 to 5.0 mm	1
309.521	Extraction Screw, conical	1
309.520	Extraction Screw, conical	1
309.530	Extraction Screw, conical	2
314.030	Screwdriver Shaft, hexagonal, \varnothing 2.5 mm	1
314.150	Screwdriver Shaft, hexagonal, \varnothing 3.5 mm	1
314.116	Screwdriver Shaft Stardrive 3.5, T15	1
03.900.042	Screwdriver Shaft Stardrive, T25	1
311.440	T-Handle with Quick Coupling	1

Extraction Module		Units
01.900.023	Extraction Module for Screws \varnothing 5.0/6.0/6.5/7.0/7.3	
68.900.023	Extraction Module for Screws \varnothing 5.0/6.0/6.5/7.0/7.3 mm	1
309.450	Hollow Reamer, complete, for Screws \varnothing 4.0 to 5.0 mm	1
309.065	Hollow Reamer, complete, for Screws \varnothing 6.0 to 7.0 mm	1
309.480	Spare Reamer Tube, for No. 309.450	1
309.068	Spare Reamer Tube, for No. 309.065	1
309.490	Extraction Bolt, for Screws \varnothing 4.0 to 5.0 mm	1
309.069	Extraction Bolt, for Screws \varnothing 6.0 to 7.3 mm	1
309.530	Extraction Screw, conical	2
309.520	Extraction Screw, conical	1
309.521	Extraction Screw, conical	1
314.150	Screwdriver Shaft, hexagonal, \varnothing 3.5 mm	1
03.900.032	Screwdriver Shaft, hexagonal, \varnothing 4.0 mm	1
03.900.042	Screwdriver Shaft Stardrive, T25	1
03.900.044	Screwdriver Shaft Stardrive, T40	1
311.440	T-Handle with Quick Coupling	1

Instruments		Units
398.650	Pliers for Screw Removal, length 205 mm	1
398.651	Pliers for Screw Removal, narrow	1
399.680	Gouge, width 10 mm, length 205/90 mm	1
319.390	Sharp Hook, length 155 mm	1
03.900.001	Sharp Hook, straight, length 155 mm	1
03.900.002	Lengthening for Screwdriver Shaft, length 160 mm	1
03.900.011	Extraction Pliers, small, for Screws	1
03.900.013	Extraction Pliers, large, for Screws	1
311.431	Handle with Quick Coupling	1
393.105	Universal Chuck, small, with T-Handle	1
03.607.104	Extension for Carbide Drill Bit \varnothing 4.0 mm	1
03.607.106	Extension for Carbide Drill Bit \varnothing 6.0 mm	1
03.400.000	Forceps for Soft Tissue Spreader	1
03.400.004	Retractor for Soft Tissue Spreader, right, length 35 mm	1
03.400.005	Retractor for Soft Tissue Spreader, left, length 35 mm	1
03.400.010	Retractor for Soft Tissue Spreader, right, length 75 mm	1
03.400.011	Retractor for Soft Tissue Spreader, left, length 75 mm	1
03.400.024	Trocar, length 35 mm, for Soft Tissue Spreader	1
03.400.030	Trocar, length 75 mm, for Soft Tissue Spreader	1
03.607.110	Drill Suction Device	1
03.607.025	Drill Sleeve 2.5, clip-on, for No. 03.607.110	1
03.607.035	Drill Sleeve 3.5, clip-on, for No. 03.607.110	1
03.607.040	Drill Sleeve 4.0, clip-on, for No. 03.607.110	1
03.607.048	Drill Sleeve 4.8, clip-on, for No. 03.607.110	1
03.607.060	Drill Sleeve 6.0, clip-on, for No. 03.607.110	1
68.900.020	Insert for Standard Screw Extraction Set, for Vario Case	1
68.900.040	Insert for Standard Screw Extraction Set, for Vario Case	1
68.900.024	Auxiliary Bin for Extraction Set	optional

Vario Case Frame and Lid	
689.507	Lid (Stainless Steel), size 1/1, for Vario Case
689.508	Vario Case, Framing, size 1/1, height 45 mm
689.510	Vario Case, Framing, size 1/1, height 88 mm
689.511	Vario Case, Framing, size 1/1, height 126 mm

Drill bits for metal	
309.503S	HSS Drill Bit Ø 2.5 mm, sterile
309.504S	HSS Drill Bit Ø 3.5 mm, sterile
309.506S	HSS Drill Bit Ø 4.8 mm, sterile
309.004S	Carbide Drill Bit Ø 4.0 mm, sterile
309.006S	Carbide Drill Bit Ø 6.0 mm, sterile

Pins	
309.070	Spare Centering Pin, f/No. 309.150
309.170	Spare Centering Pin, f/No. 309.200
309.270	Spare Centering Pin, f/No. 309.250
309.370	Spare Centering Pin, f/No. 309.035
309.470	Spare Centering Pin, f/No. 309.450
309.670	Spare Centering Pin, f/No. 309.065

The metal drill bits are supplied sterile (single use) and are not included in the set.



Synthes GmbH
Eimattstrasse 3
CH-4436 Oberdorf
www.synthes.com

Presented by:

